

Project Report 2009

Voith Turbo Wind GmbH & Co. KG

Same Dimensions but 30% more Output

BARD Develops New Drive Concept for its Wind Power System BARD 5.0 in Cooperation with Voith

In the wind power plant manufacturer BARD, Voith Turbo has found another partner for the WinDrive, which has recently received the Hermes Award. Both companies have agreed to jointly develop a drive concept for the driveline of the wind turbine "BARD 5.0."

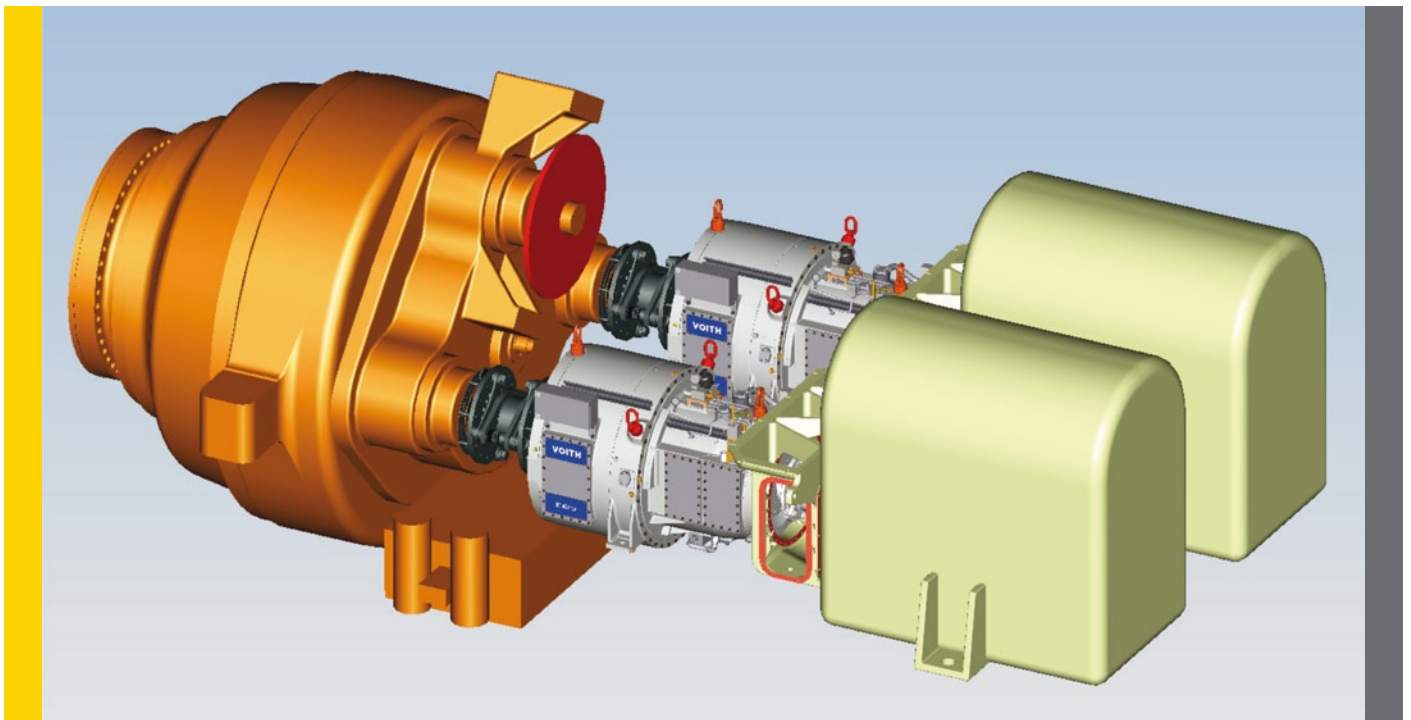

BARD 6.5 drive concept with Voith WinDrive

The BARD Group is developing the technology of its wind power station BARD 5.0 further. Thanks to a new and more efficient drive concept that retains the original rotor diameter of 122 meters and a hub height of 90 meters, the resource 'wind' can soon be utilized even more effectively.

The further development of the existing drive system "Bard 5.0" to an increased output of up to 6.5 MW (7 MVA) is an important step towards higher commercial viability of offshore wind power systems. The central component in the driveline of the turbine will be the Voith WinDrive, which is used in a BARD wind turbine for the first time.

The BARD-Group and Voith Turbo Wind GmbH & Co. KG are thus working on a 6.5 MW (7 MVA) offshore system that utilizes WinDrive technology. Delivery is scheduled for spring 2010.

"To us, the Voith WinDrive technology represents the optimum synergy of all existing technologies combined with the latest innovations," was BARD's statement on the reasons for this cooperation. "With the WinDrive system of Voith Turbo we get very closely to the requirements of energy suppliers for power station characteristics of wind parks."

The WinDrive of Voith Turbo Wind GmbH & Co KG is a variable-speed planetary gear with a torque con-

verter. Its key function is to control and convert the variable-speed input of the wind turbine rotor into a constant output speed for driving synchronous generators. Depending on the wind speed, the WinDrive adjusts the wind rotor to its most efficient operating point and its highest efficiency. At nominal power, the WinDrive acts as a back-up for controlling torque limitations.

Thanks to the WinDrive technology, it has for the first time been possible to use synchronous generators that are directly coupled to the grid and power station-approved for wind turbines. As a result, all required criteria for feeding electricity into the grid are fully met.

The upgraded wind power stations are expected to enter service in offshore projects of the BARD Group over the next few years. Apart from the already approved project "BARD Offshore 1," the BARD Group has meanwhile submitted further applications for approval to the relevant German authority (BSH Federal Maritime and Hydrographic Agency). The total output of all future projects will amount to over 3,000 Megawatt. Applications for three further parks for the Netherlands part of the North Sea are underway. "BARD Offshore 1" will be the first commercial wind park in Germany.



BARD 5.0 offshore wind energy system



Voith WinDrive